



## WatchDog for photovoltaic units Avoiding idle times with the G4UF900V01

### Problem

When light conditions are right and the skies are clear, the addition of the individual voltages generated by serial photovoltaic modules delivers high voltages. However, the efficiency of the inverters drops when conditions change to such an extent that minimum voltages cannot be achieved and the inverter and its control subsequently require more power than the photovoltaic system itself is able to deliver.

### Task

The direct-current side of photovoltaic systems switched in series needs to be monitored over a voltage range of up to 900V. In order to prevent power loss from the inverter when there is insufficient sunlight, it is necessary to deactivate the photovoltaic system at a defined minimum voltage. The system must be prevented from connecting to the national grid before it is possible to operate the inverter efficiently.

### Solution

With the WatchDog G4UF900V01, TELE is offering a voltage monitoring relay that has been adapted to the specific demands of photovoltaic systems. When the voltage generated is too low, WatchDog reports the shortfall to the inverter or control and any power loss during poor light conditions is avoided. The G4UF900V01 also has a low intrinsic consumption and may be reliably operated within a measuring range of up to 900V.

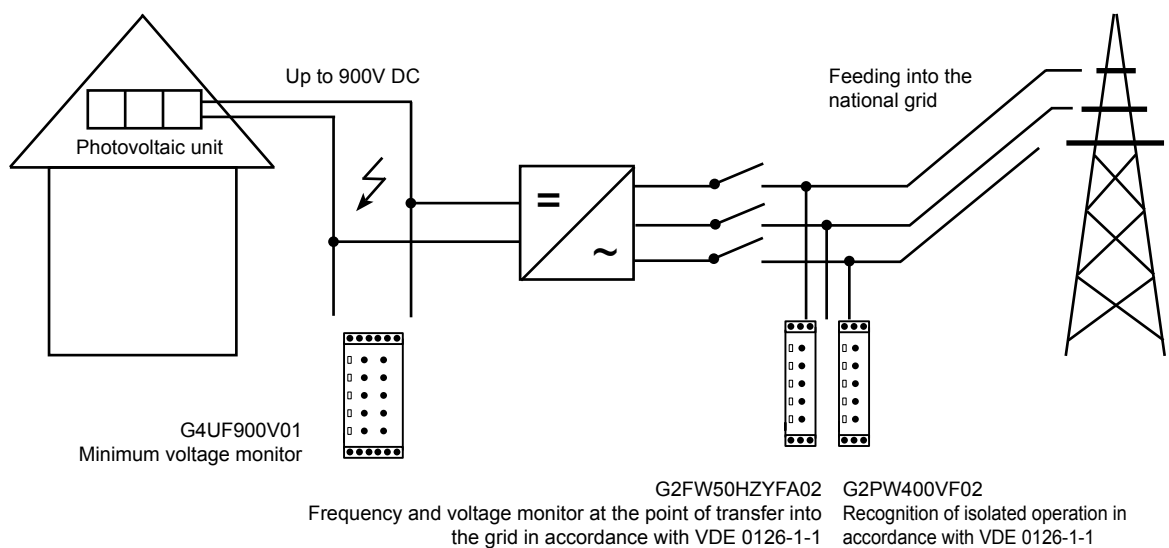

### Modules



G4UF900V01  
Art.No. 2394505